

Duobond Display Technology Co.,Ltd

PRODUCT SPECIFICATION

MODEL NAME: DBT070AIV30L8-B

Date: 2021/11/23

Version: 1.0

Preliminary Specification

Final Specification

FOR CUSTOMER	
CUSTOMER APPROVED	

PREPARED BY	CHECKED BY	APPROVED BY	DATE

ALL RIGHTS STRICTLY RESERVED. ANY PORTION OF THIS PAPER SHALL NOT BE REPRODUCED, COPIED, OR TRANSFORMED TO ANY OTHER FORMS WITHOUT PERMISSION FROM DUOBOND DISPLAY TECHNOLOGY Co., Ltd.

Record of Revisions

Rev	Date	Sub-Model	Description of change
V01	Nov. 23 th 2021	DBT070AIV30L8-B	Preliminary Product Specification was first issued.

Table of contents

- 1. General description**
- 2. Absolute maximum ratings**
- 3. Optical characteristics**
- 4. Block diagram**
- 5 Interface pin connection**
- 6. Electrical characteristics**
- 7. Reliability test items**
- 8. Outline dimension**
- 9. General precaution**
- 10. Package Specification**
- 11. Visual Specification**

1. General description

1.1 Introduction

Duobond Display model DBT070AIV30L8-B is a color active matrix thin film transistor (TFT) liquid crystal display (LCD) that uses amorphous silicon TFT as a switching device. This model is composed of a TFT LCD panel, a driving circuit and a back light system. This TFT LCD has a 7.0 (15:9) inch diagonally measured active display area with WVGA (800 horizontal by 480 vertical pixel) resolution.

1.2 Features

- 7 (15:9 diagonal) inch configuration
- 8bits LVDS interface
- LED Backlight Driver
- Up/Down, Left/Right reversion selection
- RoHS Compliance

1.3 Applications

- Mobile NB,GPS
- Personal Navigation Device
- Multimedia applications and others AV system

1.4 General information

Item	Specification	Unit
Outline Dimension	170.0 x 106.30x 6.60 (Typ.)	mm
Display area	152.40(H) x 91.44(V)	mm
Number of Pixel	800 RGB(H) x 480(V)	pixels
Pixel pitch	0.1905(H) x 0.1905(V)	mm
Pixel arrangement	RGB Vertical stripe	
Display mode	Normally Black	
Surface treatment	Antiglare, Hard-Coating(3H)	
Weight	TBD(Typ.)	g
Back-light	Single LED (Side-Light type)	
Power Consumption	B/L System 1.9(Max.)	w

1.5 Mechanical Information

item	Min.	Typ.	Max.	Unit	
Module Size	Horizontal(H)	169.8	170.0	170.2	mm
	Vertical(V)	106.10	106.30	106.50	mm
	Depth(D)	6.40	6.60	6.80	mm

2.0 ABSOLUTE MAXIMUM RATINGS

2.1 Electrical Absolute Rating

2.1.1 TFT LCD Module

Item	Symbol	Min.	Max.	Unit.	Note
Power supply voltage	VCC	-0.3	4.5	V	GND=0
	VGH	-0.3	40	V	GND=0
	VGL	-20	0.3	V	GND=0
	AVDD	0.5	15	V	AGND=0
Logic Signal Input Level	V1	-0.3	VCC+0.3	V	

2.1.2 Back-Light Unit

Item	Symbol	MIN.	TYP.	MAX.	Unit	Note
Forward voltage	VLED	9	12.0	15	V	(1)(2)(3)
Forward current	If	--	NA		mA	(1)(2)(3)
Power Consumption	PBL	--	NA		mW	

Note:

(1) Permanent damage may occur to the LCD module if beyond this specification. Functional operation should be restricted to the conditions described under normal operating conditions.

(2) $T_a = 25 \pm 2^\circ\text{C}$

(3) Test Condition: LED current

2.2 Environment Absolute Rating

Item	Symbol	Min.	Max.	Unit	Remarks
Operating Temperature	Topa	-30	+85	$^\circ\text{C}$	
Storage Temperature	Tstg	-30	+85	$^\circ\text{C}$	

3.0 OPTICAL CHARACTERISTICS

3.1 Optical specification:

Item	Symbol	Temp.	Min.	Typ.	Max.	Unit	Condition
Response Time	Tr	25°C	--	11	--	msec	$\theta = 0^\circ, \varphi = 0^\circ$ (Note 1,3)
	Tf	25°C	--	9	--		
Contrast Rate	Cr	25°C	800	1000	--	--	$\theta = 0^\circ, \varphi = 0^\circ$ LED:ON, LIGHT:OFF(Note1,2)
Brightness	YL	25°C	730	800		Cd/m2	(IL=*mA)(Note1,4)
Visual angle range front and rear	θ	25°C	$(\theta_L) 80$ $(\theta_R) 80$			De-gree	$\phi = 0^\circ, CR \geq 10$ LED:ON LIGHT:OFF(Note 1,4)
Visual angle range left and right	θ	25°C	$(\theta_U) 80$ $(\theta_D) 80$			De-gree	$\phi = 90^\circ, CR \geq 10$ LED:ON LIGHT:OFF(Note 1,4)
Brightness uniformity	BUNI		75			%	$\Theta = 0$ (Note5,7)
Visual angle			All				(Note 6)
Item	Symbol	Transmissive			Conditions		
		Min.	Typ.	Max.			
Red	XR				Reference: LCD Panel, CIE (x, y) chromaticity (Note 1,4)		
	YR						
Green	XG						
	YG						
Blue	XB						
	YB						
White	XW	0.315	0.345	0.375			
	YW	0.335	0.365	0.395			

3.2 Measuring Condition

Measuring surrounding: dark room ,LED current IL :*mA

Ambient temperature: 25±2oC

15min. warm-up time.

3.3 Measuring Equipment

FPM520 of Westar Display technologies, INC., which utilized SR-3 for Chromaticity and BM-5A for other optical characteristics. Measuring spot size: 20 ~ 21 mm

Note (1) Definition of Viewing Angle :

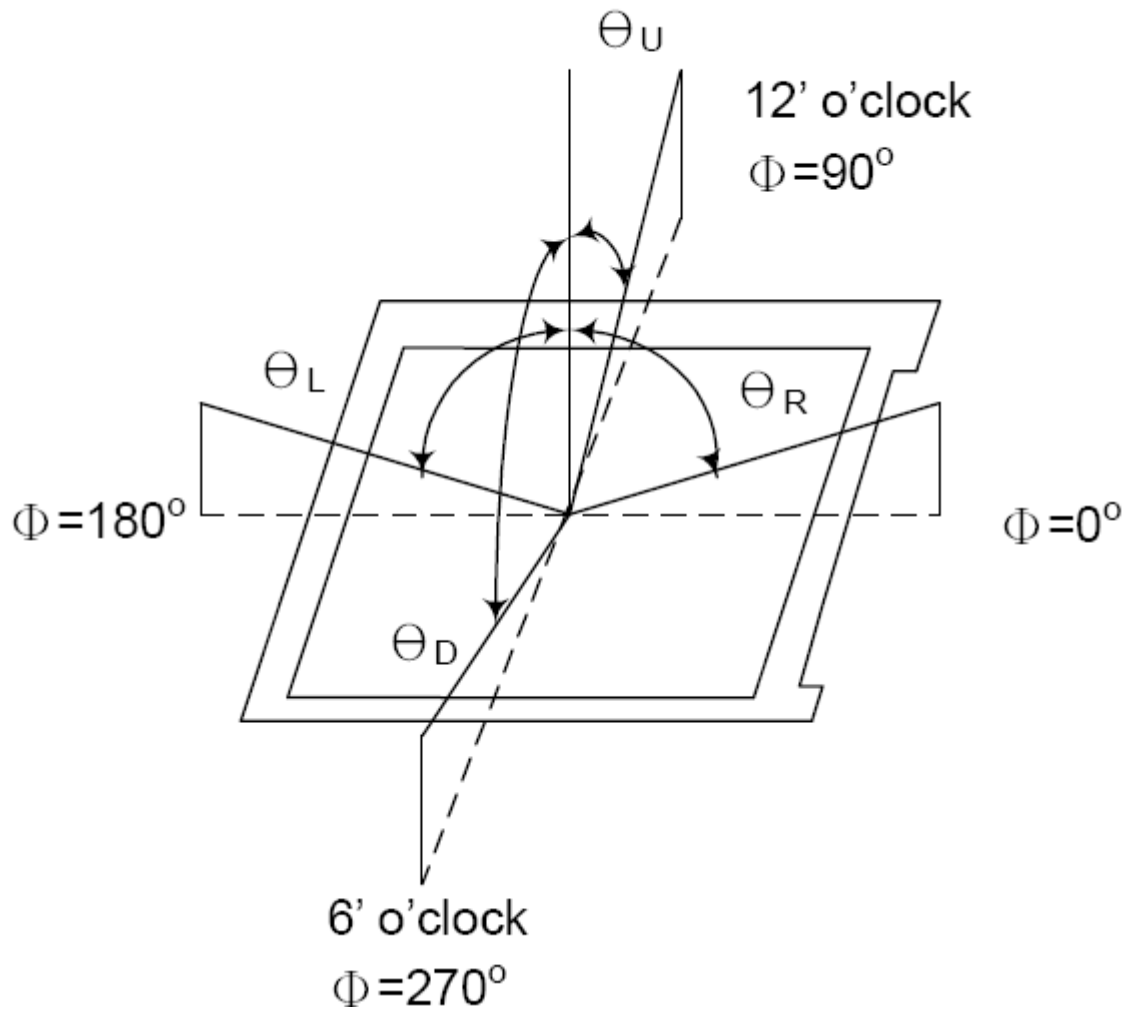

Note (2) Definition of Contrast Ratio (CR):
Measured at the center point of panel

$$CR = \frac{\text{Luminance with all pixels white}}{\text{Luminance with all pixels black}}$$

Note (3) Definition of Response Time: Sum of TR and TF

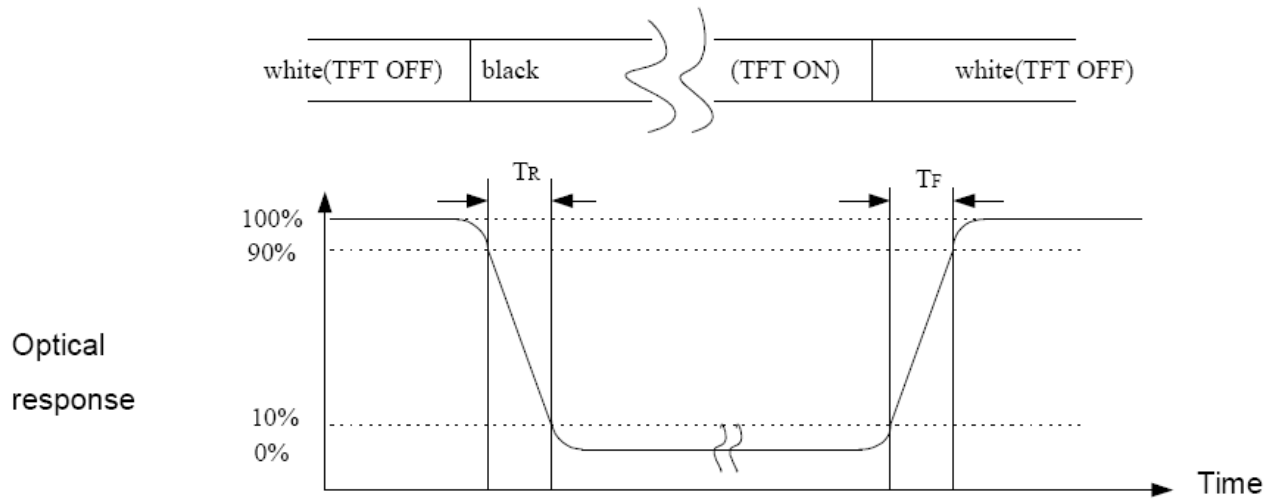

Note (4) Definition of optical measurement setup

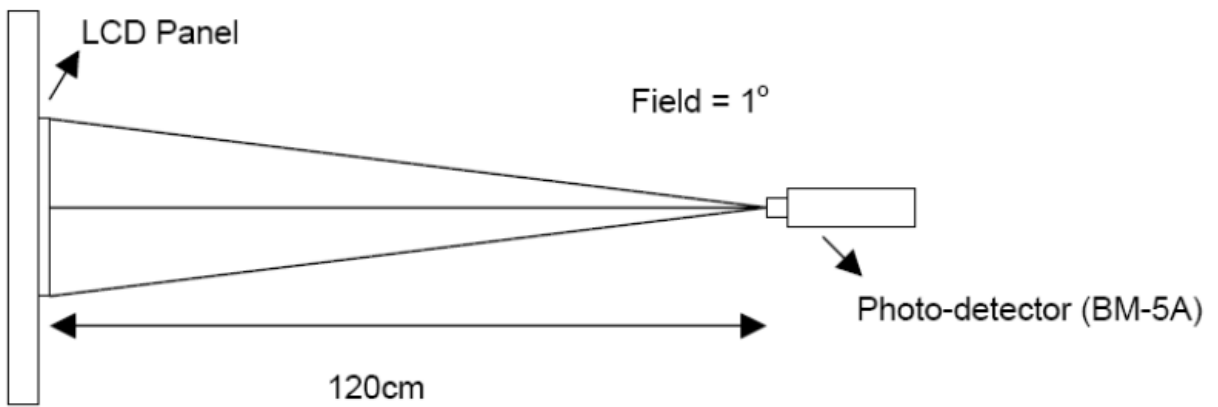

Note (5) Definition of brightness uniformity

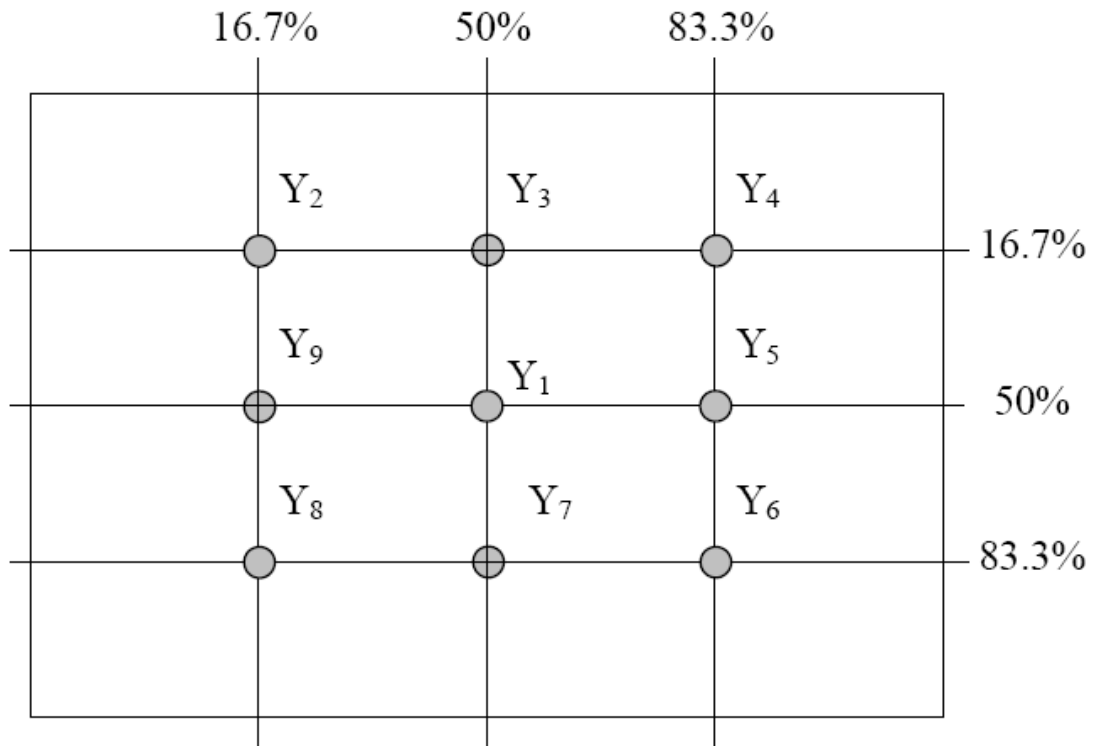

$$\text{Luminance uniformity} = \frac{(\text{Min Luminance of 9 points})}{(\text{Max Luminance of 9 points})} \times 100\%$$

Note (6) Rubbing Direction (The different Rubbing Direction will cause the different optimal view direction).

Note (7) Measured at the brightness of the panel when all terminals of LCD panel are electrically open.

4.0 BLOCK DIAGRAM

4.1 TFT LCD Module

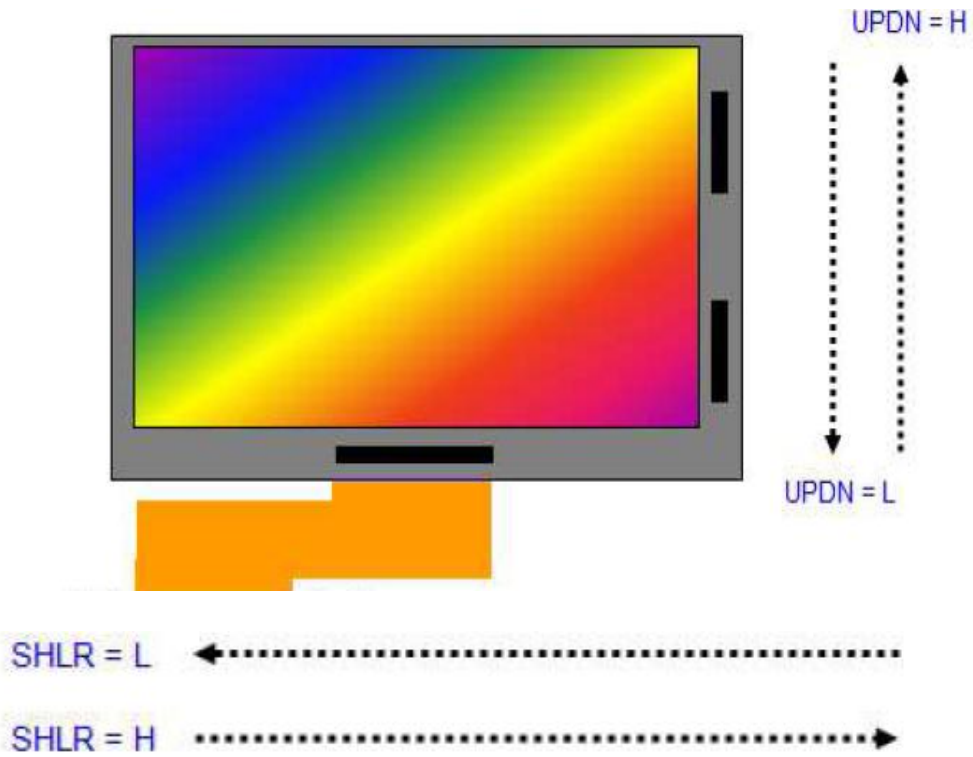

4.2 Pixel Format

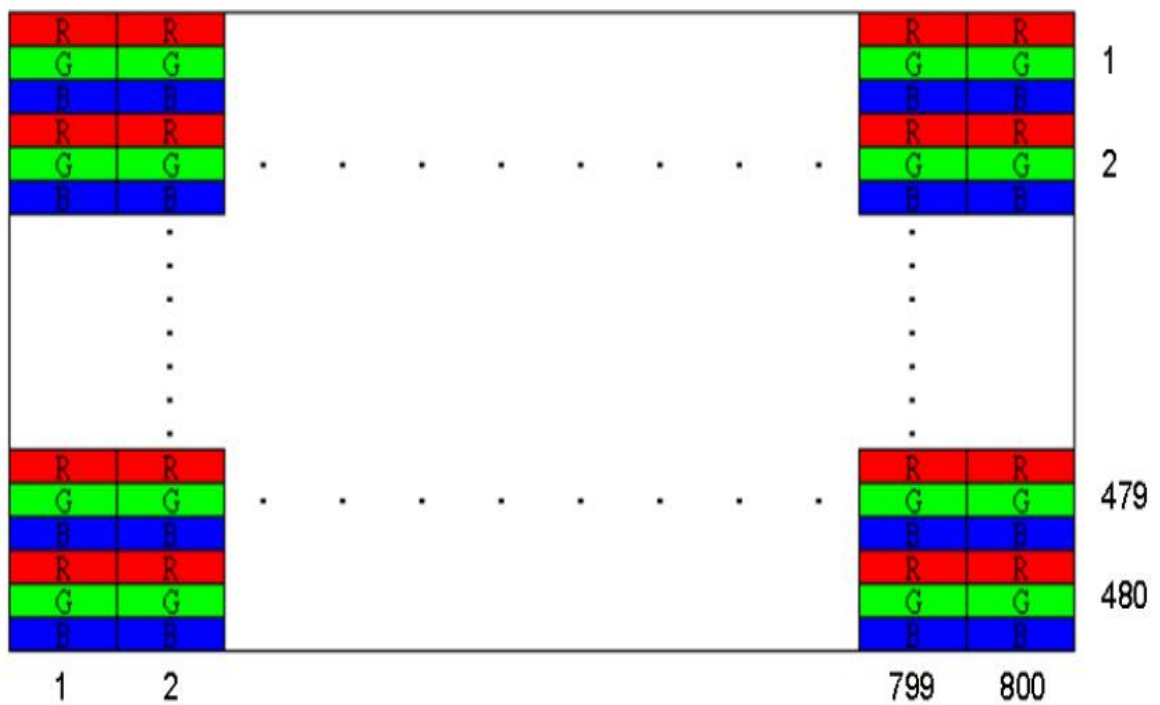

5.0 INTERFACE PIN CONNECTION

5.1 TFT LCD Module CN (Input signal): FPC Down Connector, (F1-X30SSLA-HF (JAE), 30pin, pitch = 1.0mm)

Pin No.	Symbol	I/O	Function	Remark
1	LED+	P	Backlight Driver Power Supply 12V	
2	LED+	P	Backlight Driver Power Supply 12V	
3	LED+	P	Backlight Driver Power Supply 12V	
4	NC	---	No connection	
5	GND	P	Ground	
6	LED-EN	I	Backlight Driver Enable signal	
7	PWM	I	Backlight Brightness Control signal	
8	NC	---	No connection	
9	NC	---	No connection	
10	GND	P	Ground	
11	PIND3	I	+ LVDS differential data input	
12	NIND3	I	- LVDS differential data input	
13	GND	P	Ground	
14	CLKP	I	+ LVDS differential clock input	
15	CLKN	I	- LVDS differential clock input	
16	GND	P	Ground	
17	PIND2	I	+ LVDS differential data input	
18	NIND2	I	- LVDS differential data input	
19	GND	P	Ground	
20	PIND1	I	+ LVDS differential data input	
21	NIND1	I	- LVDS differential data input	
22	GND	P	Ground	
23	PIND0	I	+ LVDS differential data input	
24	NIND0	I	- LVDS differential data input	
25	GND	P	Ground	

26	SHLR	I	Horizontal scan control signal; H:Left to Right; L:Right to Left	
27	GND	P	Ground	
28	GND	P	Ground	
29	VCC	P	Power Voltage for digital circuit;3.3V	
30	VCC	P	Power Voltage for digital circuit;3.3V	

Note:

I:Signal Input ; O:Signal Output,. P: Power Supply

6.0 ELECTRICAL CHARACTERISTICS

6.1 TFT LCD Module

Item	Symbol	Min.	Type	Max.	Unit.	Note
Power supply voltage	VCC	3.0	3.3	3.6	V	GND=0
	VGH	19.5	20	20.5	V	GND=0
	VGL	-8.5	-8	-7.5	V	GND=0
	AVDD	12.5	13.0	13.5	V	AGND=0
Input signal voltage	Vih	0.7Vcc		Vcc	V	
	Vil	0		0.3Vcc	V	
Current of Power Supply	Idd	--	TBD	--	mA	Vcc=3.0V
	Iadd	--	12.0	26.5	mA	AVdd=10V(Black)
	Igh	--	1.0	2.0	mA	Vgh=20V
	Igl	--	1.0	2.0	mA	Vgl=-8V
LED Reverse Voltage	Vr	-		(5)		Each LED
LED Forward Current	If	-		(35)	V	Each LED

Note (1): Be sure to apply the power voltage as the power sequence spec.

Note (2): DGND=AGND=0V

6.2 AC Characteristics

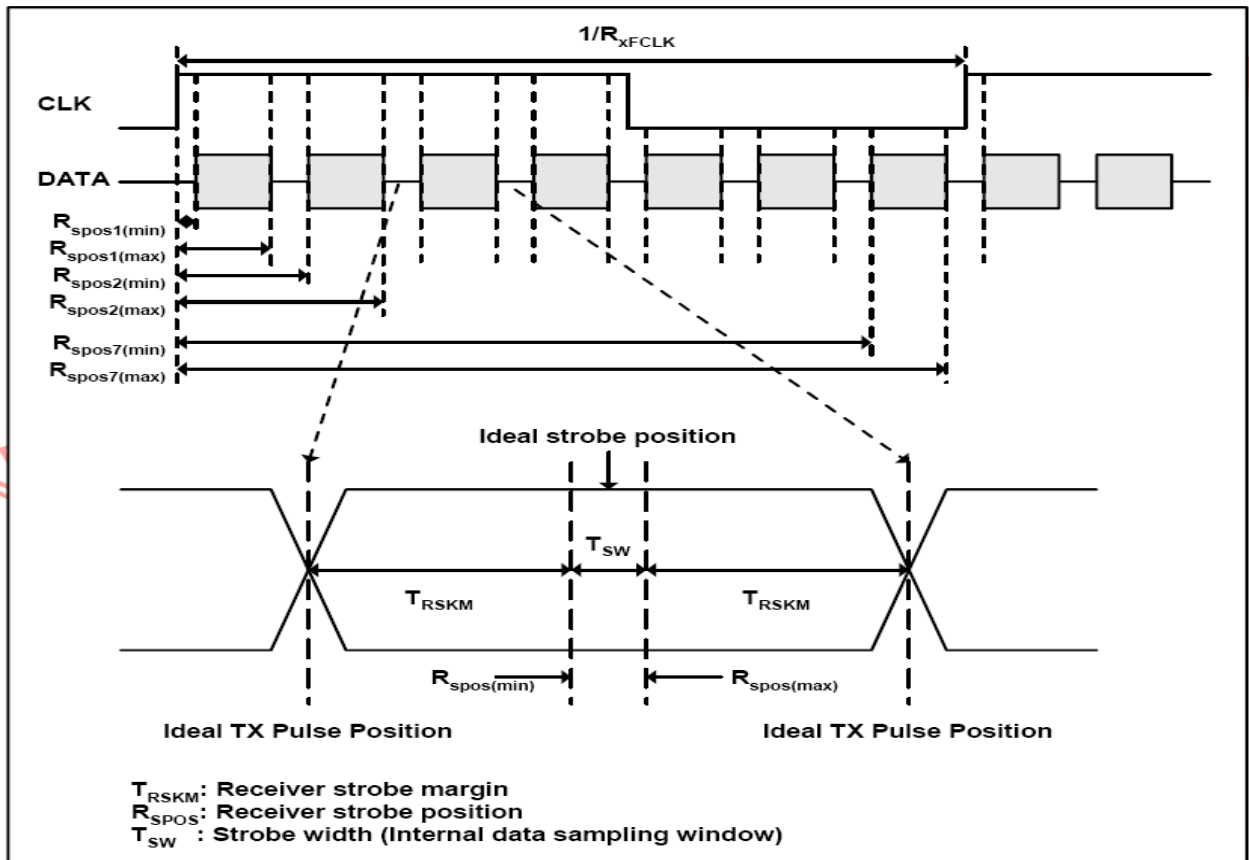
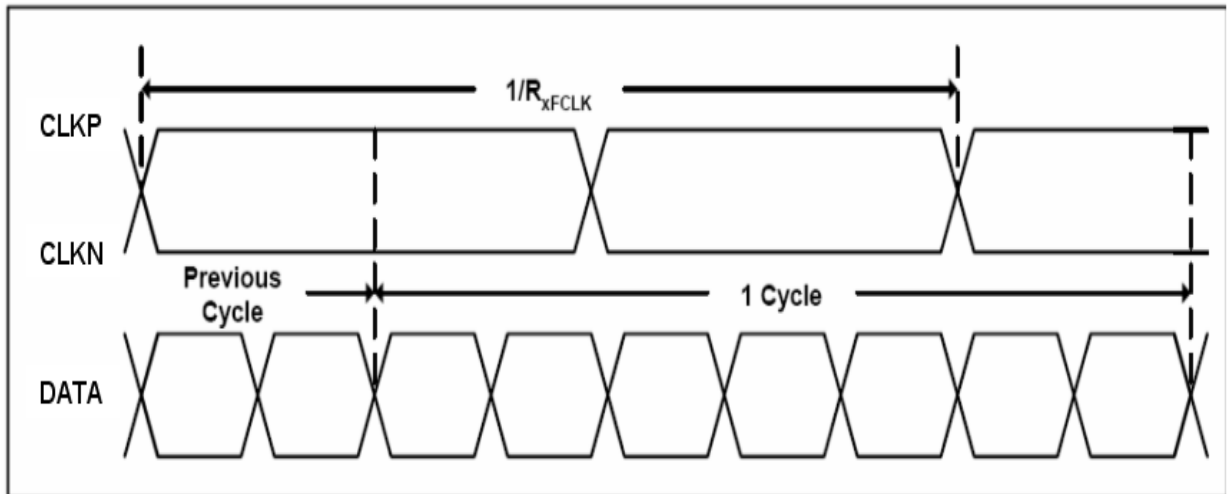

6.3:DC Electrical Characteristics

(LVDS mode: VDD = 2.7V to 3.6V, AVDD = 8V to 13.5V, AVSS=GND=0V, TA= -40 to +95°C)

Parameter	Symbol	Min.	Typ.	Max.	Unit	Condition
Differential Input high Threshold voltage	R_{XVTH}	-	-	0.2	V	$R_{XVCM}=1.2V$
Differential Input Low Threshold voltage	R_{XVTL}	-0.2	-	-	V	
Input voltage range (signaled-end)	R_{XVIN}	0.3	-	$VDD-1.2$	V	-
Differential Input common Mode voltage	R_{XVCM}	0.8	1.2	$VDD-1.2- V_{ID} /2$	V	-
Differential Input voltage	$ V_{ID} $	0.2	-	1	V	$R_{XVCM}=1.2V$
Differential Input leakage Current	$R_{V_{XIZ}}$	-10	-	+10	μA	-
LVDS Digital Operating Current	I_{ddlvds}	-	TBD	TBD	mA	Fclk=61MHz, VDD=3.3V
LVDS Digital Stand-by Current	I_{stlvds}	-	TBD	TBD	μA	Clock & all functions are stopped

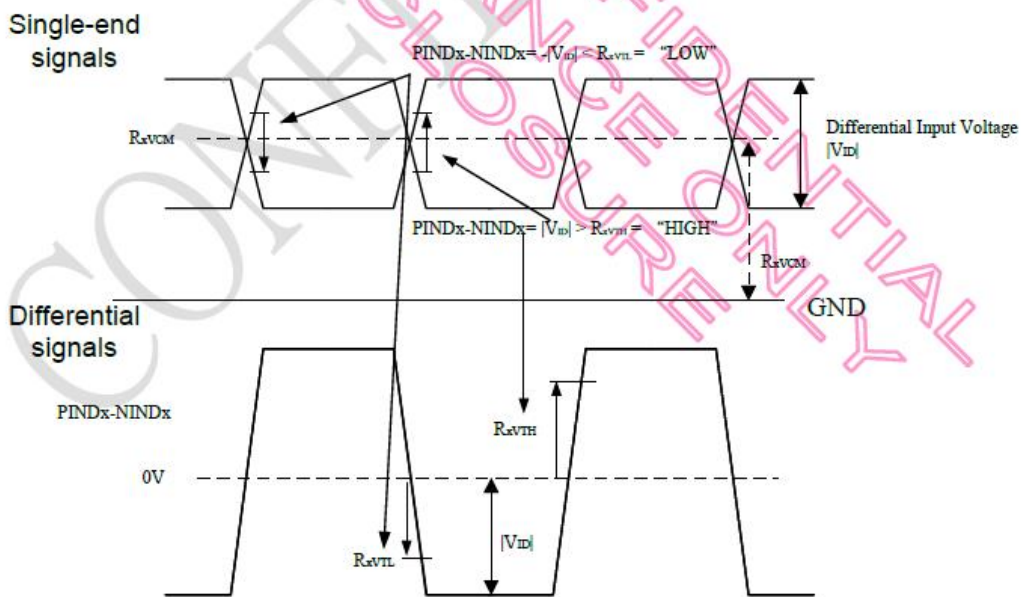

6.4 Timing Diagram of Interface Signal

6.4.1 Timing Characters

Horizontal Input Timing Table

Parameter	Symbol	Value			Unit	Note
		Min.	Typ.	Max.		
DCLK frequency	fclk	33.2	37	45	MHz	
Horizontal display area	thd	800			DCLK	
1 Horizontal Line	th	1054	1175	1395	DCLK	
HSD pulse width	thpw	1		15	DCLK	
HSD Back Porch (Blanking)	thb	48			DCLK	
HSD Front Porch	thfp	206	327	547	DCLK	

Vertical Input Timing Table

Parameter	Symbol	Value			Unit	Note
		Min.	Typ.	Max.		
Vertical display area	tvd	480			H	
VSD period time	tv	525	525	580	H	
VSD pulse width	tvpw	1		15	H	
VSD Back Porch (Blanking)	tvb	20			H	
VSD Front Porch	tvfp	25	25	80	H	

6bit LVDS input

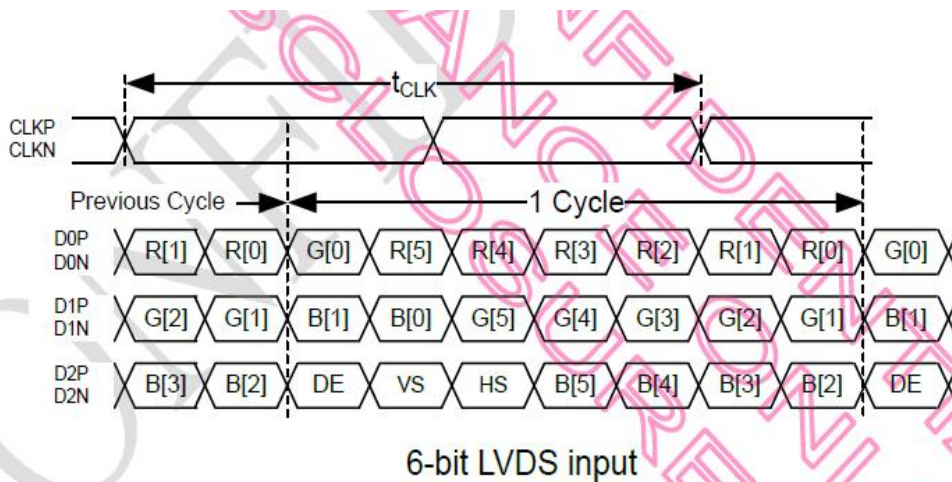

8bit LVDS input

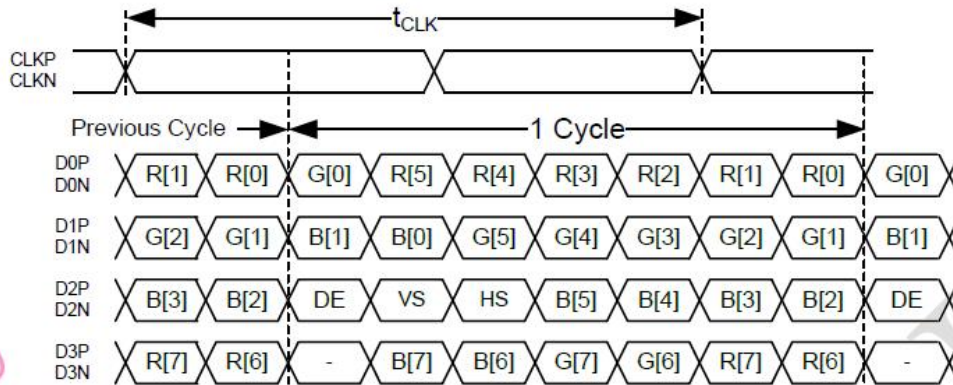

8-bit LVDS VESA input

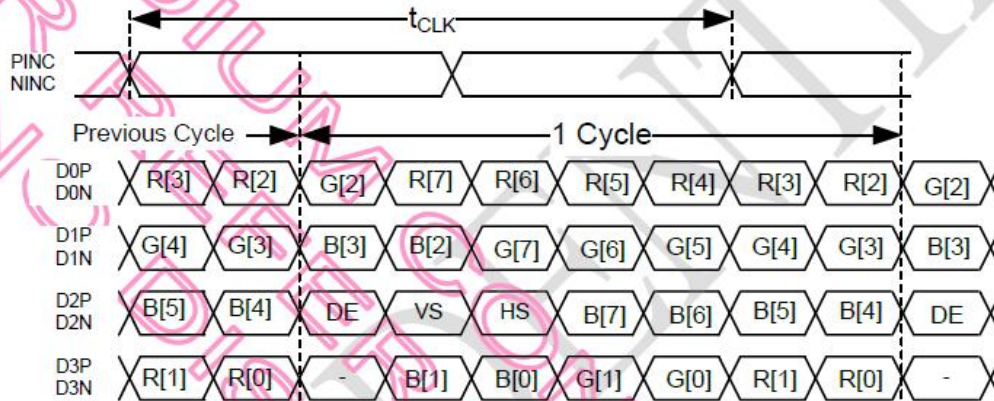

8-bit LVDS JEIDA input

Note: Support DE timing mode only, SYNC mode not supported.

6.5 Power ON/Off Sequence

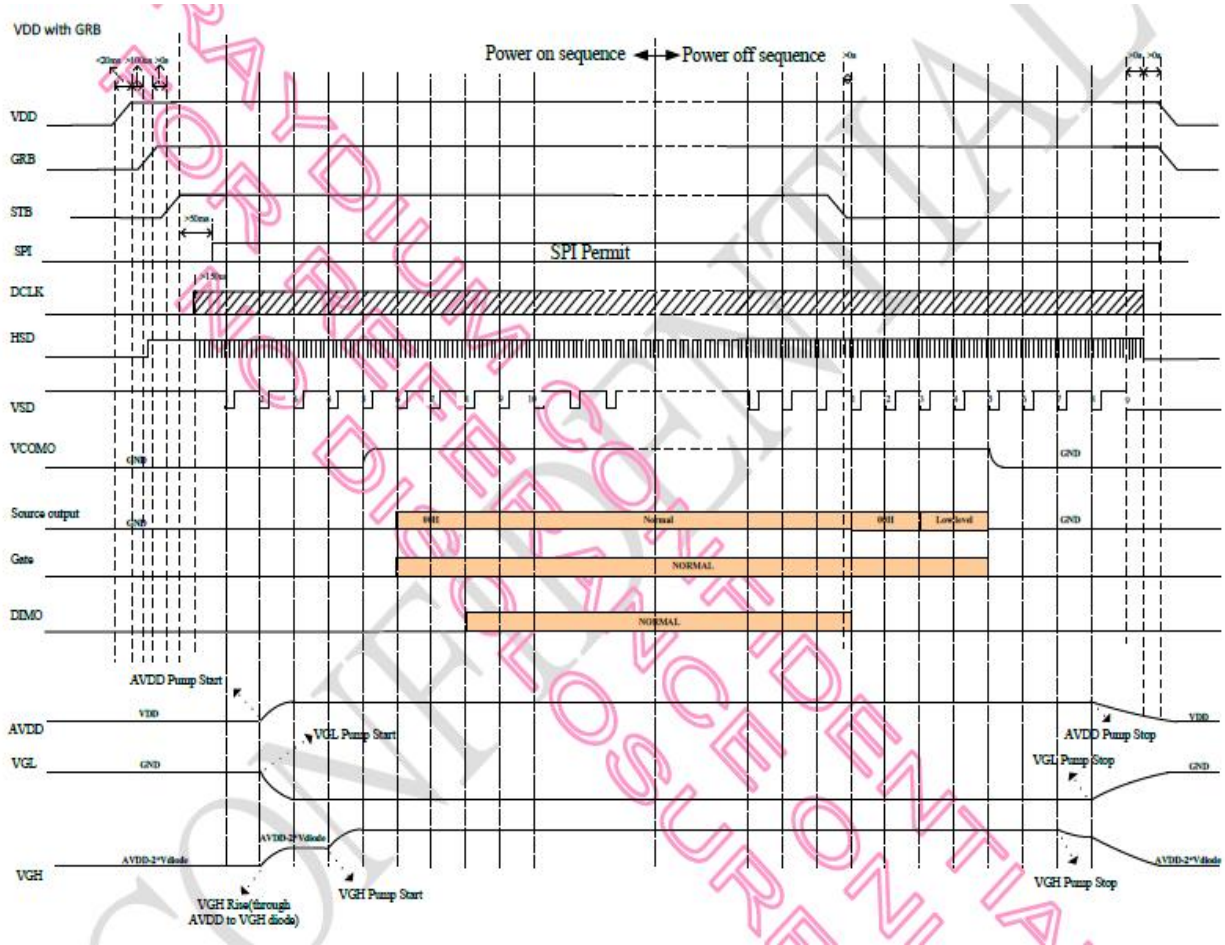

7.0 Reliability test items

NO.	Item	Conditions	Remark	
1	High Temperature Storage	Ta=+85°C,240hrs	Inspection after 2~4 hours storage at room temperature, the sample shall be free from defects 1. Air bubble in the LCD 2. Sealleak 3. non-display 4. missing segmnents 5. glass crack 6. current idd is twice higher than initial value.	
2	Low Temperature Storage	Ta=-30°C,240hrs		
3	High Temperature Operation	Ta=+85°C,240hrs		
4	Low Temperature Operation	Ta=-30°C,240hrs		
5	High Temperature and High Humidity(Operation)	Ta=+60°C, 90%RH, 240hrs		
6	Thermal cycling Test (non operation)	-30°C (30min)→+85°C (30min),100cycles		
7	Electrostatic discharge	200V 200pf(0ohm) 1time/each terminal		
8	Vibration	1. Random: 1.04 Grms,5~500HZ, X/Y/Z,30min/each direction 2. Sine: Freq. Range:8~33.3hz Stoke:1.3mm Sweep:2.9G,33.3~400HZ X/Z:2hr,Y:4hr,cyc:15min		
9	Shock	100G,6ms,±X, ±Y, ±Z 3 times for each direction		JIS C7021,A-10 (Condition)
10	Vibration(with carton)	Random:0.015G ^ 2/HZ, 5~200HZ -6dB/octave,200~400HZ XYZ each dirction:2hr		
11	Drop (with carton)	Height:60cm 1corner,3edges,6surfaces		JIS Z0202

Note:

1. There is no display function NG issue occurred, all the cosmetic specification is judged before the reliability stress.
2. the test samples should be applied to only one test item
3. for damp proof test, Pure water(resistance>10M ohm)should be used
4. in case of malfunction defect caused by ESD damage, if it would be recovered to normal state after resetting, it would be judged as a good part
5. Failure Judgment Criterion: Basic Specification, Electrical Characteristic, Mechanical Charateristic, Optical Characteristic

8.0 OUTLINE DIMENSION

Outline Dimension:

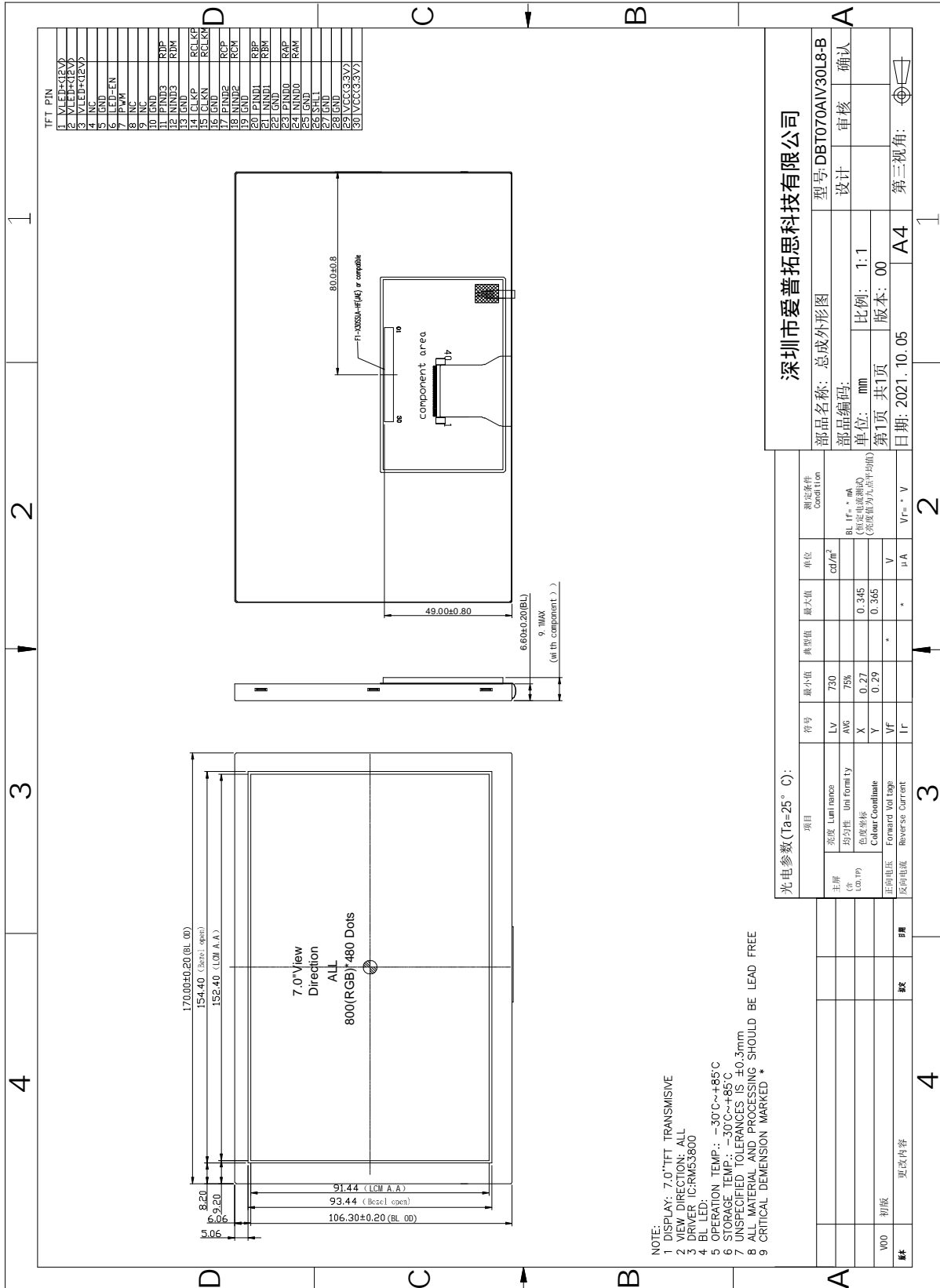

9.0 GENERAL PRECAUTION

9.1 Use Restriction

This product is not authorized for use in life supporting systems, aircraft navigation control systems, military systems and any other application where performance failure could be life threatening or otherwise catastrophic.

9.2 Disassembling or Modification

Do not disassemble or modify the module. It may damage sensitive parts inside LCD module, and may cause scratches or dust on the display. HannStar does not warrant the module, if customers disassemble or modify the module.

9.3 Breakage of LCD Panel

9.3.1. If LCD panel is broken and liquid crystal spills out, do not ingest or inhale liquid crystal, and do not contact liquid crystal with skin.

9.3.2. If liquid crystal contacts mouth or eyes, rinse out with water immediately.

9.3.3. If liquid crystal contacts skin or cloths, wash it off immediately with alcohol and rinse thoroughly with water.

9.3.4. Handle carefully with chips of glass that may cause injury, when the glass is broken.

9.4 Electric Shock

9.4.1. Disconnect power supply before handling LCD module.

9.4.2. Do not pull or fold the LED cable.

9.4.3. Do not touch the parts inside LCD modules and the fluorescent LED's connector or cables in order to prevent electric shock.

9.5 Absolute Maximum Ratings and Power Protection Circuit

9.5.1. Do not exceed the absolute maximum rating values, such as the supply voltage variation, input voltage variation, variation in parts' parameters, environmental temperature, etc., otherwise LCD module may be damaged. **9.5.2.** Please do not leave LCD module in the environment of high humidity and high temperature for a long time. **9.5.3.** It's recommended to employ protection circuit for power supply.

9.6 Operation

9.6.1 Do not touch, push or rub the polarizer with anything harder than HB pencil lead.

9.6.2 Use fingerstalls of soft gloves in order to keep clean display quality, when persons handle the LCD module for incoming inspection or assembly.

9.6.3 When the surface is dusty, please wipe gently with absorbent cotton or other soft material.

9.6.4 Wipe off saliva or water drops as soon as possible. If saliva or water drops contact with polarizer for a long time, they may causes deformation or color fading.

9.6.5 When cleaning the adhesives, please use absorbent cotton wetted with a little petroleum benzine or other adequate solvent.

9.7 Mechanism

Please mount LCD module by using mouting holes arranged in four corners tightly.

9.8 Static Electricity

9.8.1 Protection film must remove very slowly from the surface of LCD module to prevent from electrostatic occurrence.

9.8.2. Because LCD module use CMOS-IC on circuit board and TFT-LCD panel, it is very weak to electrostatic discharge. Please be careful with electrostatic discharge. Persons who handle the module should be grounded through adequate methods.

9.9 Strong Light Exposure

The module shall not be exposed under strong light such as direct sunlight. Otherwise, display characteristics may be changed.

9.10 Disposal



When disposing LCD module, obey the local environmental regulations.

10. Package Specification

10.1 Packing format

(1) package quantity in one carton :30PCS .

11. Visuals Specification: 1) Note

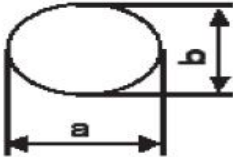
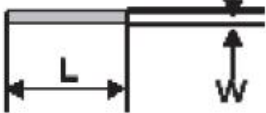
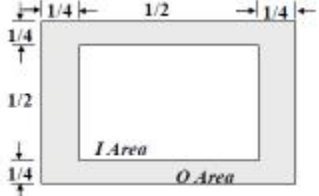
<p>General</p>	<p>1. Customer identified anomalies not defined within this inspection standard shall be reviewed by Duobond , and an additional standard shall be determined by mutual consent.</p> <p>2. This inspection standard about the image quality shall be applied to any defect within the effective viewing area and shall not be applicable to outside of the area.</p> <p>3. Inspection conditions</p> <p>Luminance : 500 Lux min.</p> <p>Inspection distance : 300 mm.</p> <p>Temperature : 25±5°C</p> <p>Direction : Directly above</p>		
<p>Definition of inspection item</p>	<p>Dot defect</p>	<p>Bright dot defect</p>	<p>The dot is constantly “on” when power applied to the LCD, even when all “Black” data sent to the screen. Inspection tool: 5% Transparency neutral density filter.Count dot: If the dot is visible through the filter. Don’t count dot: If the dot is not visible through the filter.</p>  <p style="text-align: right;">■ dot defect</p>
		<p>Black dot defect</p>	<p>The dot is constantly “off” when power applied to the LCD, even when all “White” data sent to the screen.</p>
		<p>Adjacent dot</p>	<p>Adjacent dot defect is defined as two or more bright dot defects or black dot defects.</p>  <p style="text-align: right;">■ dot defect</p>
<p>External inspection</p>	<p>Bubble ,scratch(foreign Particle polarizer, Cell, Backlight)</p>		<p>Visible operating (all pixels “Black” or “White”) and non operating.</p>
	<p>Appearance inspection</p>	<p>Does not satisfy the value at the spec.</p>	
<p>Others</p>	<p>LED wires</p>	<p>Damaged to the LED wires, connector, pin, functional failure or appearance failure.</p>	
<p>Definition of Size</p>	<p>Definition of circle :  $d = (a + b) / 2$</p> <p>definition of linear size </p> <p>definition Area I/O </p>		

2) Standard

Classification		Inspection item		Judgment Standard		
Defect (in LCD glass)	Dot defect	Area		I	O	
		Bright dots(Note: Visible under:ND5%) 1:D≤0.15mm:No count); D>0.15mm acceptable: 2		N≤0	N≤2	
		Dark dots (0.15mm<D≤0.3mm), D>0.3mm Not allowable		N≤3		
		Bright dot-2Adjacent		N≤0		
		Dark dot-2Adjacent		N≤0		
		Dark or bright dots-3 and more adjacent(note6)		N≤0		
		Total bright and dark dots		N≤5		
		Minimum distance between bright dots		5mm		
		Minimum distance between dark dots		5mm		
		Minimum distance between bright and bright dots		5mm		
	Other	White dot ,dark dot (circle)	Size (mm)		Acceptable number	
			d≤0.2		Neglected	
			0.2mm<D≤0.3mm		N≤4	
			0.3mm<D≤0.4mm		N≤2	
			D>0.4mm		Not allowable	
Visual defect	Foreign partial	Circular foreign material: dark/bright sport		Visible under:ND5% 1:D≤0.15mm:No count 2:0.15mm<D≤0.3mm,N≤4 3:D>0.3mm:Not allowable		
		Linear foreign material: bright or dark line		Invisible under ND5% 0.1mm<W≤0.3mm, 0.3mm<L≤1.5mm,N≤4 Visible under ND5% 0.05mm≤w≤0.1mm, 0.3mm≤L≤0.7mm,N≤4		
	Polarizer	Linear scratch		1:BM:No Count 2:Pixel area 0.05mm≤w≤0.2mm, 1.0mm≤L≤5.0mm,N≤4		
		Bubble peeling		1:BM:No Count 2:Pixel area 0.15mm≤D<0.3mm,N≤4		
	Mura & leak				ND5%	